

Schalplan Decke ü. 1.OG Haus A - Teil 3
M 1:50

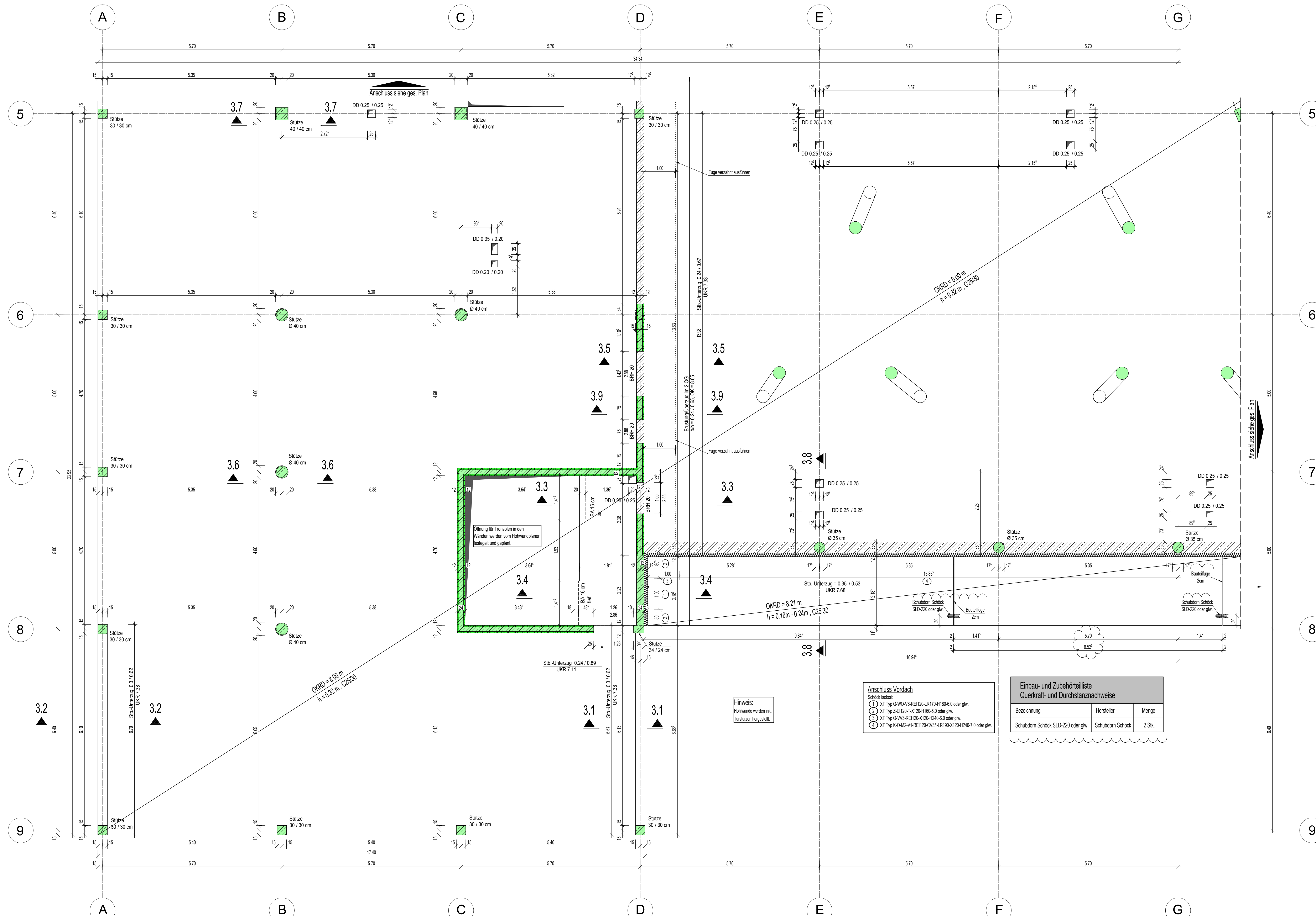

- Anschluss Vordach**
- Schick Isokorb
 - XT Typ Q-WO-VS-REI120-LR170-H180-6.0 oder glw.
 - XT Typ ZEI100-T-X120-H180-5.0 oder glw.
 - XT Typ Q-VS-REI120-X120-H240-6.0 oder glw.
 - XT Typ K-AM-VI-REI120-CV35-LR190-X120-H240-7.0 oder glw.

Einbau- und Zubehörteile
Querkraft- und Durchstanznachweise

Bezeichnung	Hersteller	Menge
Schubdom Schöck SLD-220 oder glw.	Schubdom Schöck	2 Stk.

Schnitt 3.1 - 3.1
M 1:50

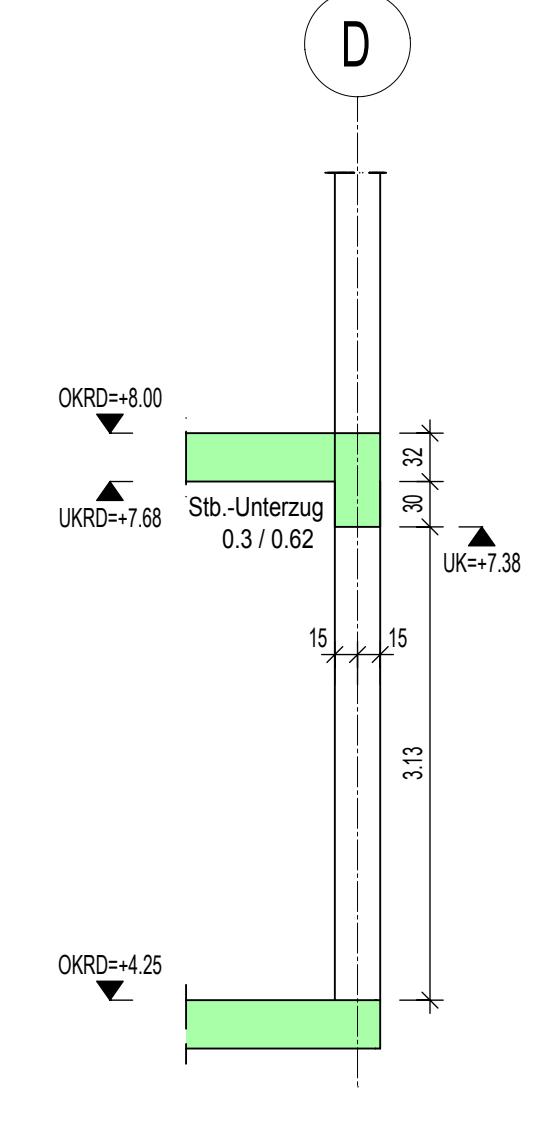

Schnitt 3.2 - 3.2
M 1:50

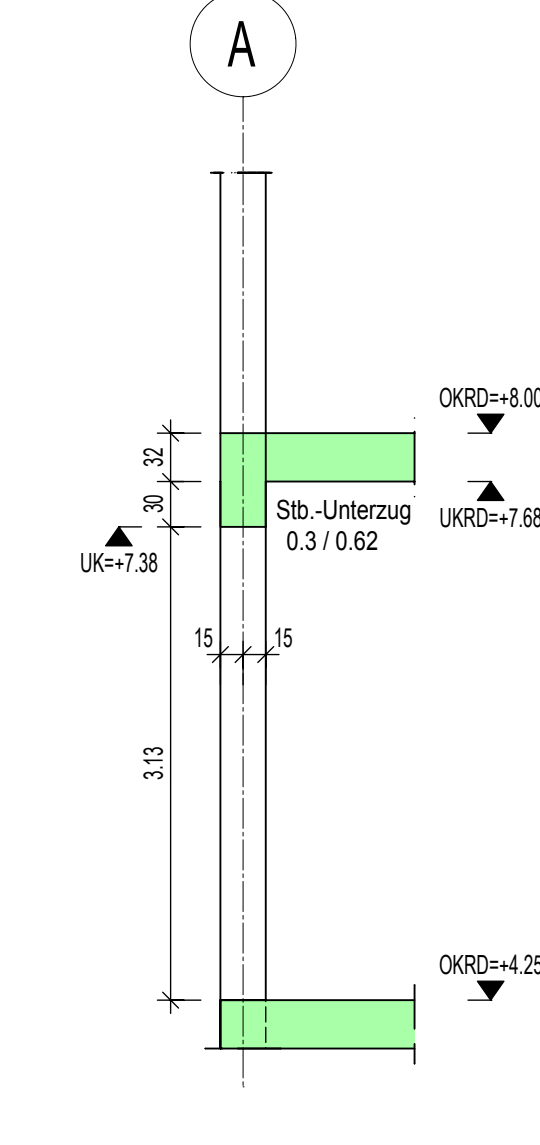

Schnitt 3.3 - 3.3
M 1:50

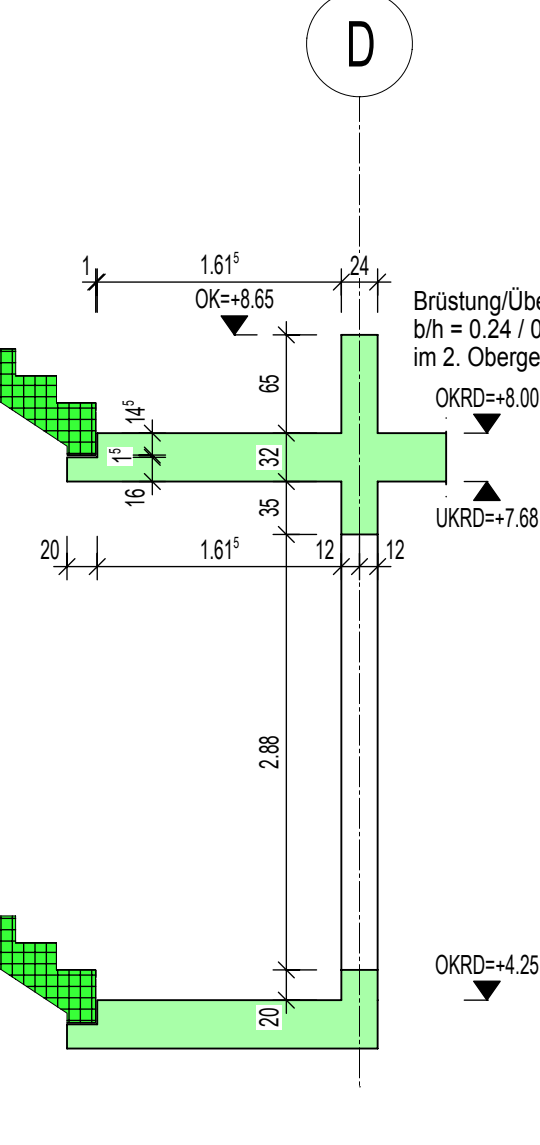

Schnitt 3.4 - 3.4
M 1:50

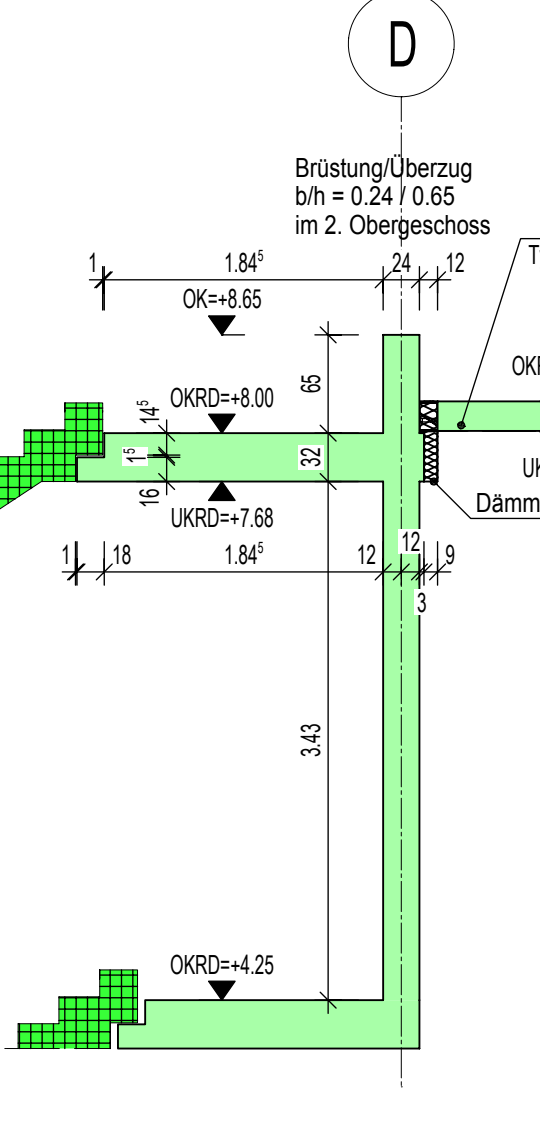

Schnitt 3.5 - 3.5
M 1:50

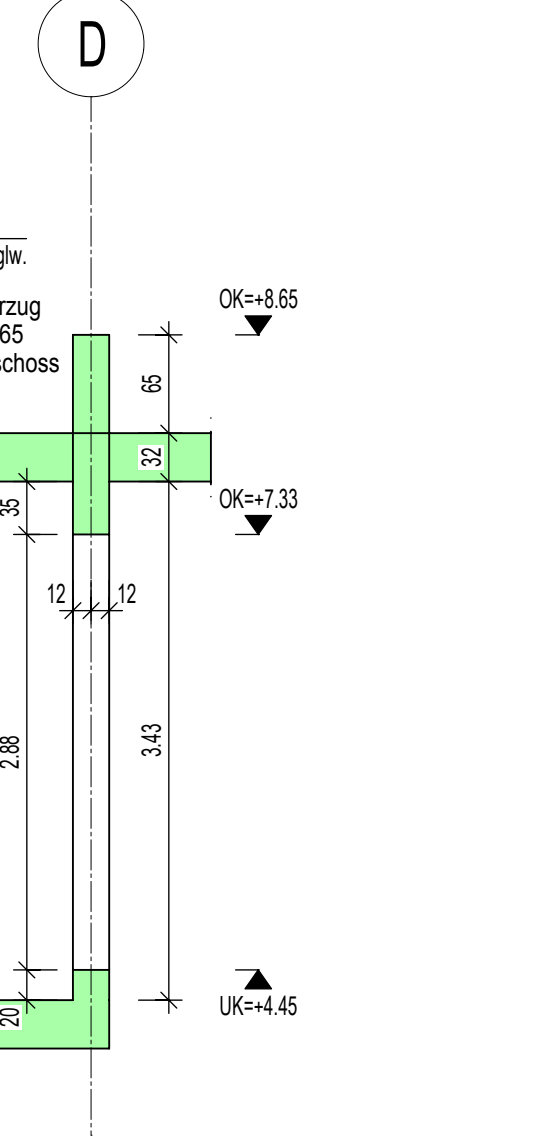

Schnitt 3.6 - 3.6
M 1:50

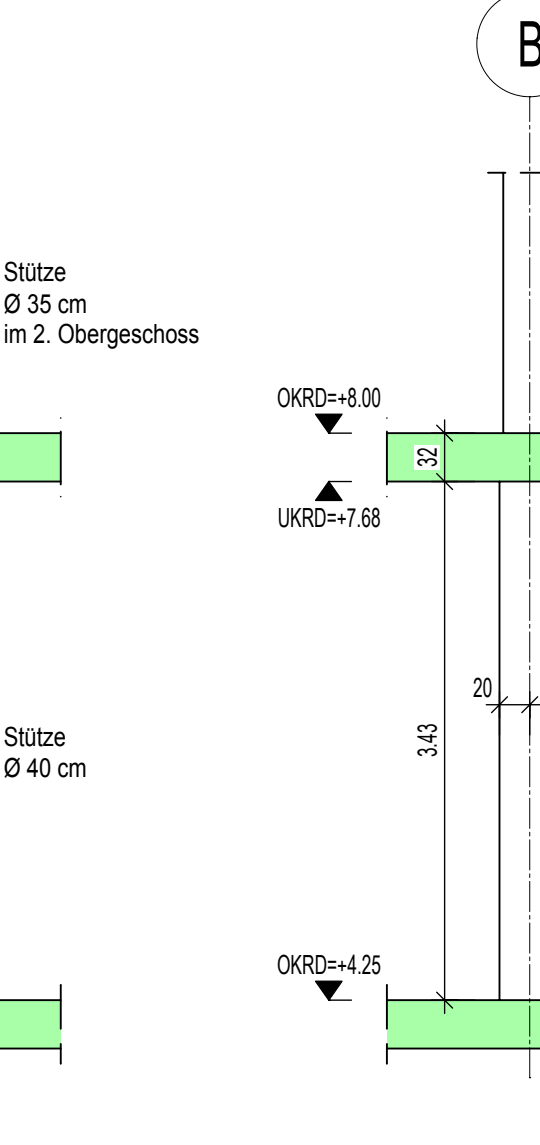

Schnitt 3.7 - 3.7
M 1:50

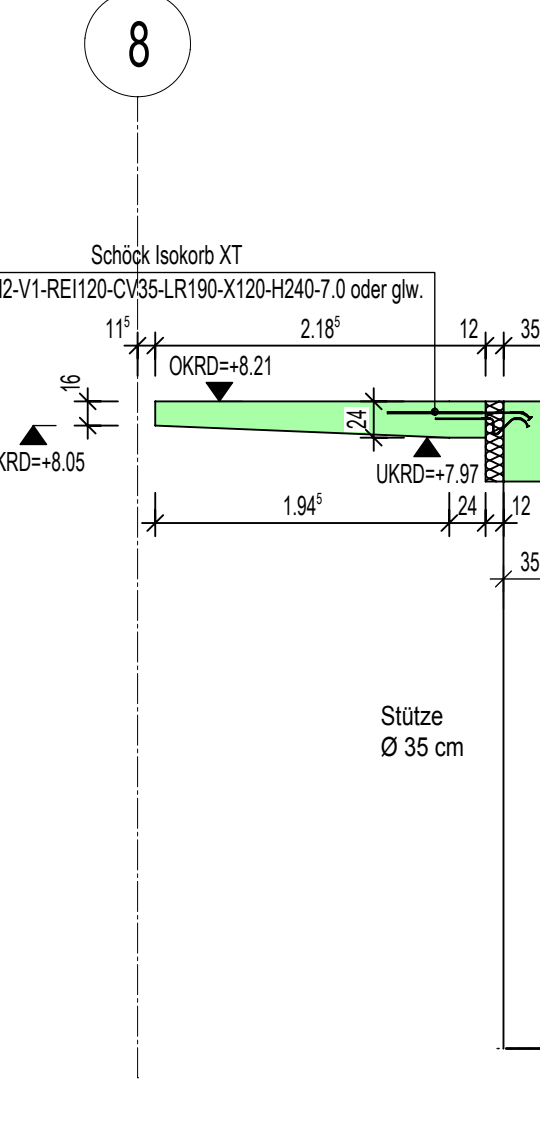

Schnitt 3.8 - 3.8
M 1:50

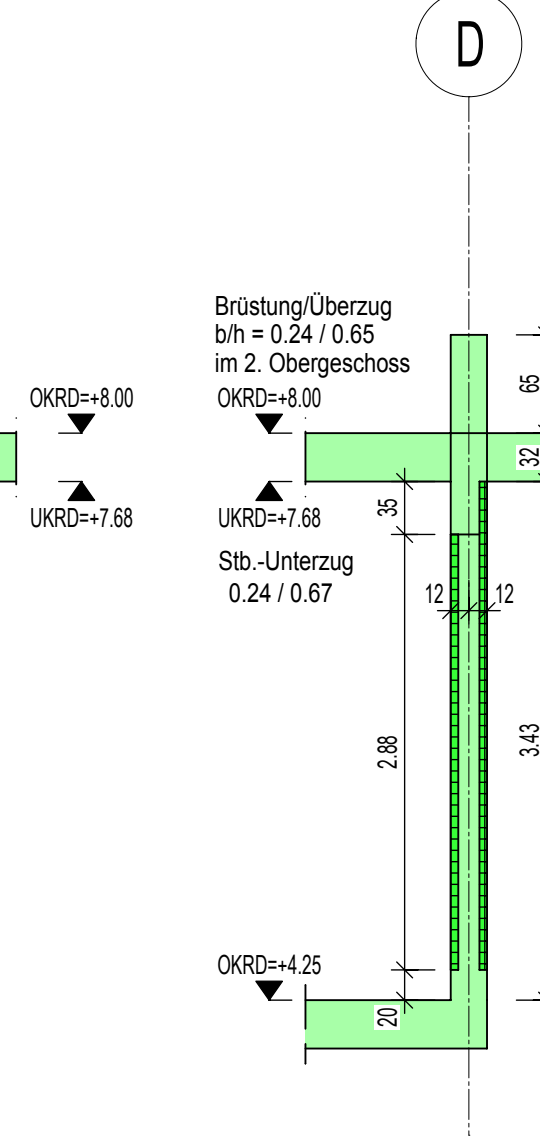

Schnitt 3.9 - 3.9
M 1:50

